

REVISIONS					
ECO NO.	CHG	LTR	CHANGES	BY	DATE

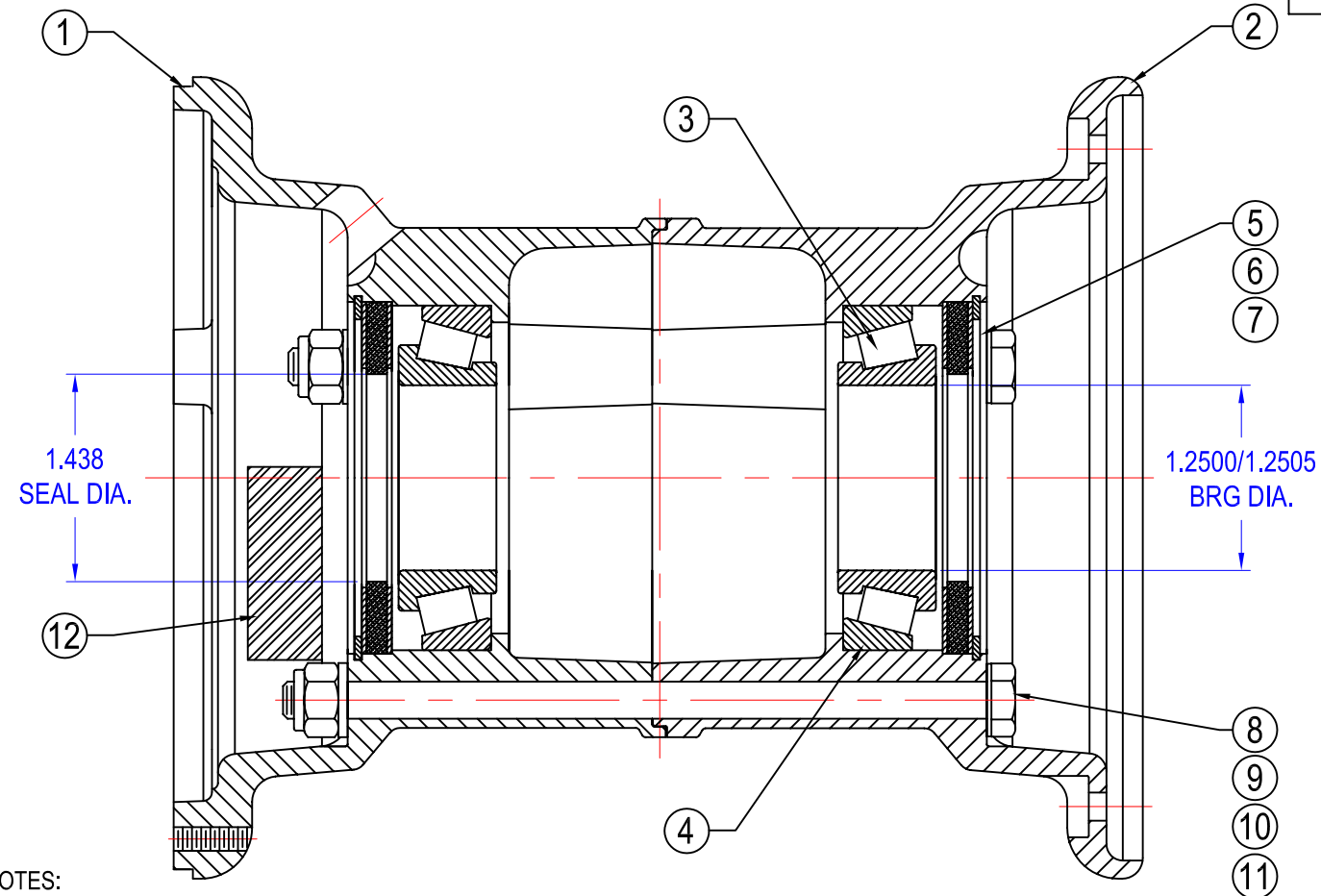

12	019-001	LABEL,WARNING	1
11	AN365-428A	NUT (MS21044-N4)	3
10	AN960-416	WASHER	3
9	AN960-416L	WASHER	3
8	AN4-46A	BOLT	3
7	010-002	FELT SEAL	2
6	011-002	SEAL RING	4
5	VH-237-S02	SNAP RING	2
4	LM67010	RACE	2
3	LM67049A	BEARING	2
2	015-022M	WHEEL HALF, OUTER	1
1	016-022M	WHEEL HALF, INNER	1
-	40-208	WHEEL ASSY	Assy
F/N	PART NO.	PART NAME	Qty

NOTES:

1. WHEEL IDENTIFIED WITH THE FOLLOWING
PART NO.: 40-208
WHEEL SIZE: 800X4 TYPE III
STATIC LOAD RATING: 1100 LBS.
DATE MFG.
SERIAL NO.
GROVE AIRCRAFT LANDING GEAR SYSTEMS INC.
EL CAJON, CALIF. 92020
TORQUE WHEEL NUTS TO 90 IN.LBS.
MFG UNDER FAA-TSO-C26d
2. PACK BEARINGS WITH AEROSHELL #22 (MIL-PRF-81322G)
3. WHEEL WEIGHT: 2.66 LBS.
4. WHEEL ASSY MUST BE EQUIPT WITH EITHER A BF.GOODRICH P/N B13-4 DRUM OR GROVE AIRCRAFT LGS INC P/N 018-013 DISC AT TIME OF INSTALLATION.
5. TIRE USAGE: 800X4, 4 PR
6. MAX INFLATION PRESSURE: 25PSI

Grove
Aircraft Landing Gear Systems inc.
1800 JOE CROSSON DRIVE, ELCAJON, CA 92020

TOLERANCE DECIMAL 0.XX= +/--.030 DECIMAL 0.XXX= +/--.010 DECIMAL 0.XXXX= +/--.005 ANGLE = 0.25 DEGREES			
SCALE: NONE	DWG NO. 40-208	REV IR	SHT 1 OF 1
FINAL ASSY			
DRW: RG 12/10/11	CHK: PN 12/19/11	APV: RG 12/19/11	

Assy, Main Wheel