

AXLE BOLT HOLE TEMPLATES

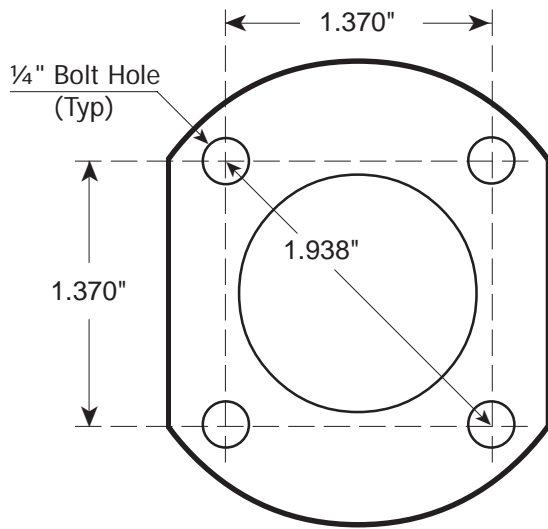

Type 1 Hole Pattern

This pattern matches axle part numbers 5010, 5011, 5012, 5013, 5014, 5014-1, 5015, 5018, 5026 and 5032.

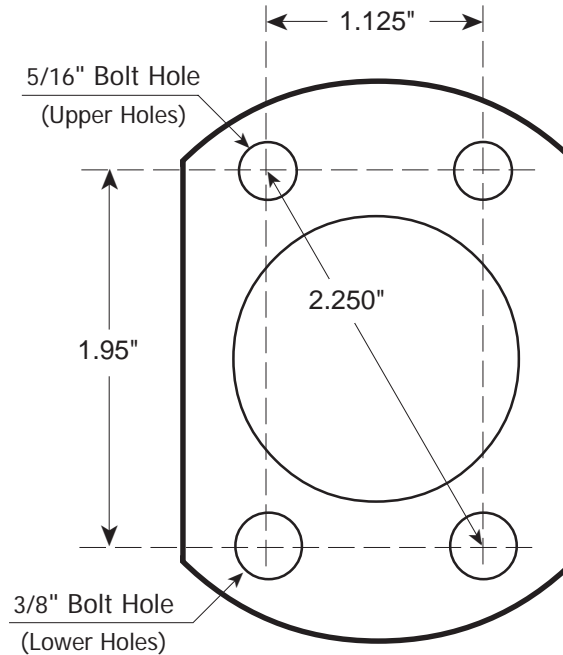

Type 2 Hole Pattern

This pattern matches axle part numbers 5016 and 5017.

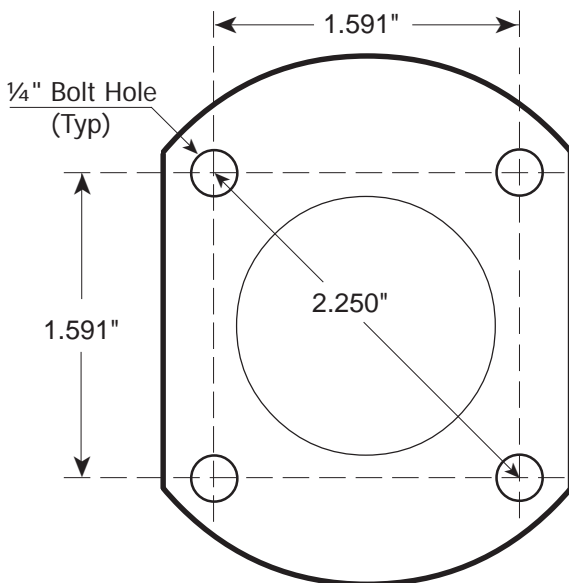

Type 3 Hole Pattern

This pattern matches axle part number 5022 and is the same as the Cub-Type hole pattern.

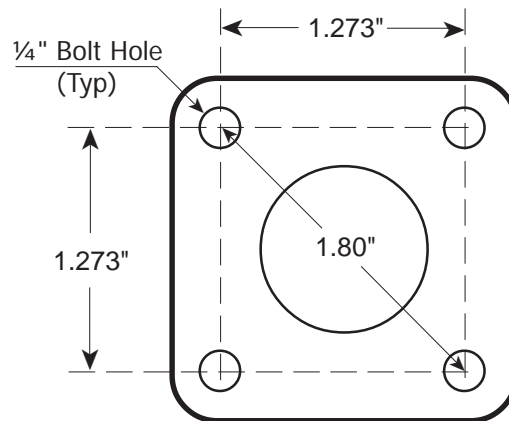

Type 4 Hole Pattern

This pattern matches axle part numbers 5030 and 5031.